



SCU-200 Control Unit

MTS-20H

MTS-20H/30H Tilt Switches & SCU-200 Control Unit

- Easy to Install - requires little maintenance
- Control Unit will interface with any tilt switch probe
- Control Unit provides at-a-glance circuit status
- Adjustable time delay prevents false indication
- Rugged and reliable welded steel probes
- NEMA 12 or optional NEMA 4 enclosure
- Optional intrinsically safe unit
- Optional stainless steel probes available

Product Information

Description

The Electro Sensors' Tilt Switch is a simple system consisting of a control unit and a sensing probe. It is widely used in the process industry to sense the presence or absence of any bulk material. Typical applications include: high or low bin level alarms, detection of transfer chute plug-up, control of material depth in crusher bowls and the sensing of alarm conditions in rock box, screen classifiers and more. Normal or safe condition may be vertical, as in a screen classifier properly loaded – an excessive level tilts the probe to indicate an alarm. Normally tilted condition is typified by material flowing on a conveyor belt – loss of material drops the probe to the vertical position to indicate alarm.

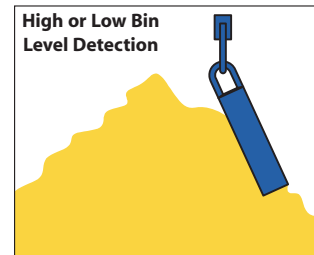

Principle of Operation

Tilt Switch Probes feature rugged welded steel construction. They are airtight, waterproof, dust and dirtproof, and have a stress relieved cable. The mercury switch inside the probe is epoxy encapsulated to seal it from even the most severe environmental conditions. The probe mounted in a vertical position has closed contacts. As it is tilted to approximately 15 degrees, contacts will open. The contacts have a maximum capacity rating of 230 Vac, 1.7 Amps. The probe is supplied with a flexible 8-foot Neoprene jacketed 18-gauge, two-wire conductor cable suitable for conduit or stand-alone wiring.

The SCU-200 Control Unit provides a safe low voltage power source for any probe. Input from the probe is switch selectable so that either tilted or vertical position may be selected as "safe." The opposite position results in alarm, following an adjustable 1-99 second relay output delay. The delay assures reliable performance, free from false alarms, because only a sustained change in the probe position will initiate an alarm. Lamps are mounted on the face of the enclosure to indicate the SAFE/ALARM status of the output relay (5 amp DPDT). The control is "fail-safe," relay failure or power loss causes an immediate alarm.

Installation Instructions

Probe may be suspended from the threaded conduit adapter hanger. Cable length should be adjusted so it won't affect tilting of the probe body. Control unit may be remotely located in any convenient place. See wiring diagram for terminal block layout. Tilt switch hangers (supplied as standard) are all welded steel to match the probe body and are threaded to screw directly onto 1/2-inch NPT conduit. Optional stainless steel hangers and probes are also available.

Auxiliary Sensor Power:

The SCU-200 Control Unit has a sensor input feature that adds to its versatility. Terminal TB2-1 is a 12 Vdc sensor supply terminal that enables the use of open collector sensors such as Hall-effect and proximity sensors with the control unit. This feature may be used in a wide variety of sensing applications where an adjustable relay output is desired when the sensor detects a target.

MTS Tilt Switches & SCU Control Unit

Time Delay Adjustment

The Relay Output Time Delay function is adjustable from 1-99 seconds. Use a small screwdriver to turn the rotary switches S2 and S3 for the desired time delay interval. Switch S2 adjusts for single seconds, and switch S3 adjusts for tens.

Example: A time delay of 14 seconds would require S3 to be set at 1 and S2 to be set at 4.

Probe Status Switch

With the probe status switch in the "A" position, the relay is energized, and the green "SAFE" lamp is lit when the probe is tilted. With the probe status switch in the "B" position, the relay is energized and the green "SAFE" lamp is lit when the probe is in a vertical position.

Standard Probe Connections

All tilt switch probes should be connected to terminals TB2-2 and TB2-3.

Alternate Sensor Connections

Sensor Power TB2-1
Sensor Signal TB2-2
Sensor Ground TB2-3

Wiring Diagram

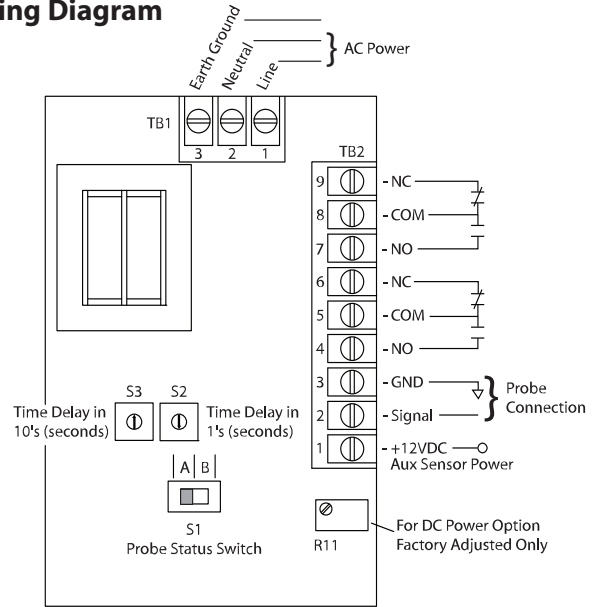

Specifications • SCU-200 Control Unit

Input Power 115 Vac \pm 10% 50/60 Hz.
Opt. 230 Vac, 12/24 Vdc
Probe Signal Voltage +12 Vdc (10 k Ω pull-up to +12 Vdc)
Auxiliary Sensor
Supply Voltage..... +12 Vdc @ 17 mA max
Relay Output DPDT Form C relay, rated 5 Amp @ 250 Vac resistive load.
Relay Status Switch Selectable
Relay Status Lamps..... 2 replaceable lamps, 28 Vac
Wiring Connections Screw barrier terminal 14 AWG max
Enclosure NEMA 12, 6 x 4 x 3 inch
NEMA 4 optional
Operating Temperature 0°C to +70°C
Storage Temperature..... -20°C to +70°C
Option Intrinsically safe available

Dimensions • SCU-200 Control Unit

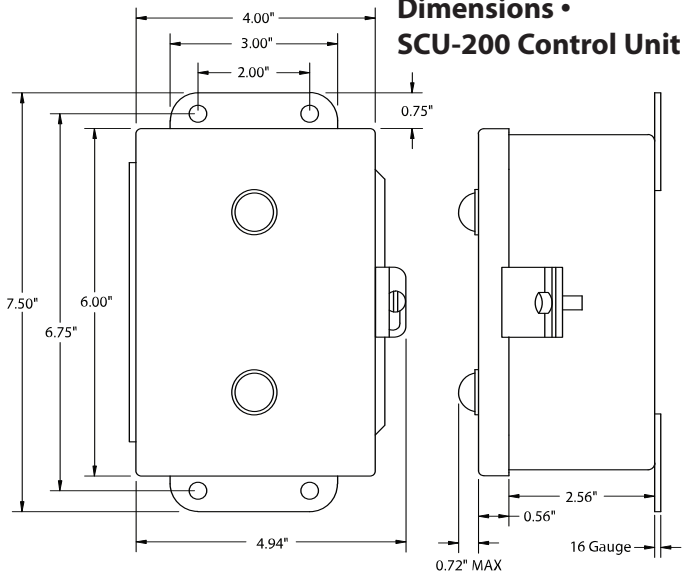

Probes	MTS-20H	MTS-30H
Contact Rating (all)	1.7 Amp max. @ 250 Vac SPST	
Contact Type	Mercury	Mercury
Probe Actuation Angle	15° \pm 5°	15° \pm 5°
Weight	18 oz.	75 oz.
Cable	8 ft., 18 gauge 2 conductor	8 ft., 18 gauge 2 conductor
Enclosure	Neoprene Steel	Neoprene Steel

Standard MTS-20H Tilt Switch with Hanger

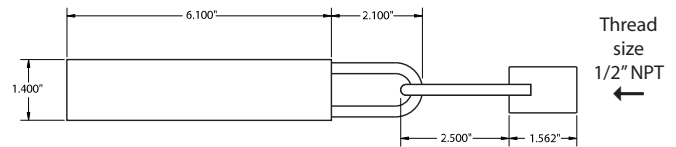

Heavy-Duty MTS-30H Tilt Switch with Hanger

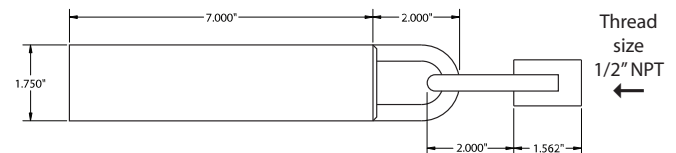

WARNING
CONTAINS MERCURY
DISPOSE ACCORDING TO LOCAL, STATE AND FEDERAL LAWS

Specifications subject to change without notice.